

Universal Platform

Platform Parts Breakdown (1997 – Present).....	2-4
Retractable Finger Auger Parts Breakdown.....	5-6
Combine Pickup Head Parts Breakdown	7-9
4 – Tube Pickup Head Layout (1997 – 1999)	10-11
Combine Pickup Head Parts Breakdown (2000 – Present)	12-14
8 – Tube Pickup Head Layout (1997 – 2014)	15-16
8 – Tube Pickup Head Layout (2015 – Present)	17-18

Return to this page by clicking the upper right corner of any page in this section.

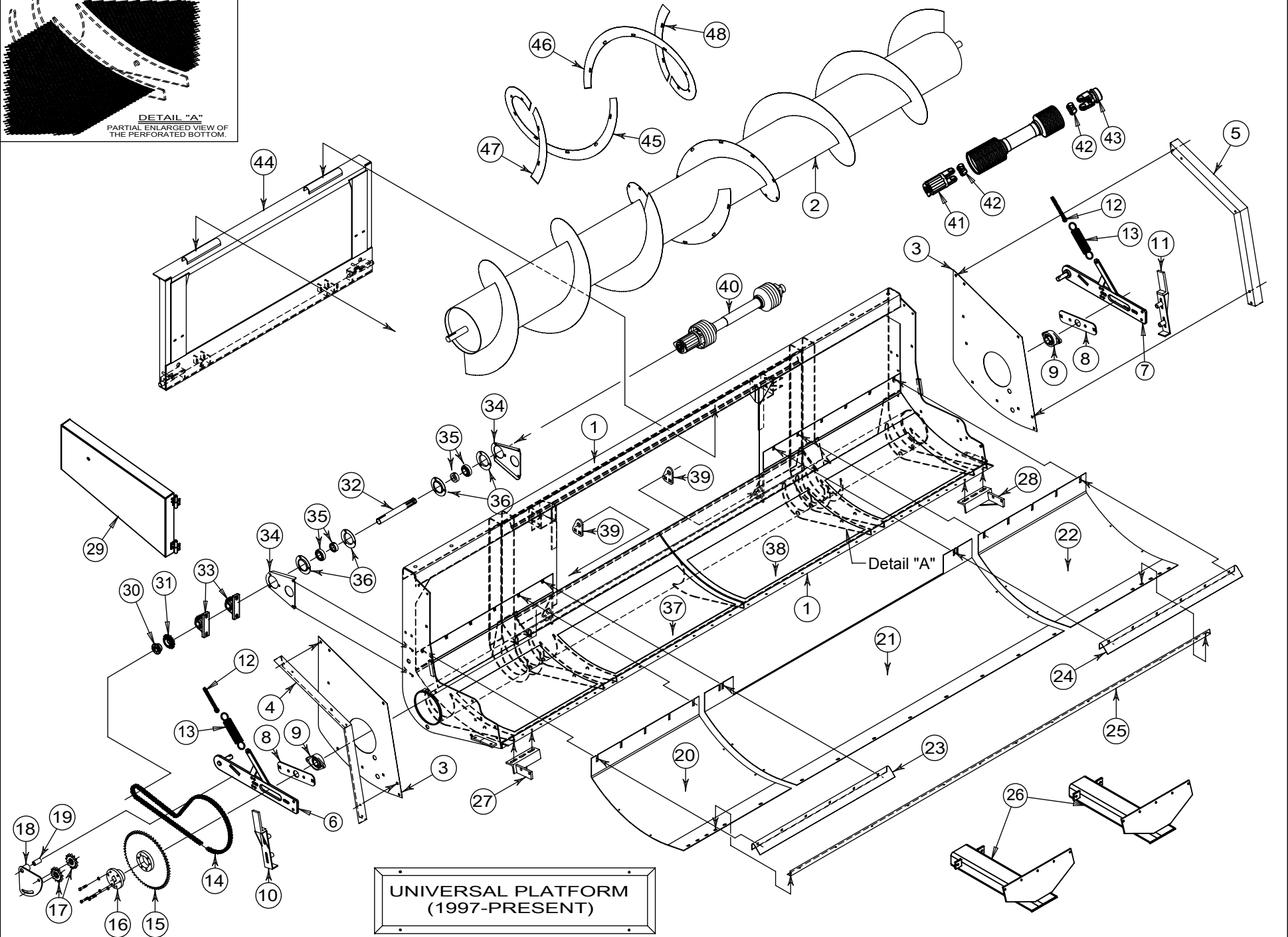
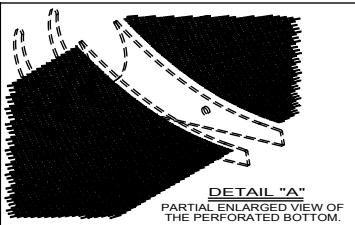

UNIVERSAL PLATFORM—148" (1997–Present)

Parts List

<u>Item No.</u>	<u>Part No.</u>	<u>Qty.</u>	<u>Description</u>
1.	400040	1	Platform Main Frame—148" Model
2.	400035	1	Auger—148" Model (with cut down center flighting)
3.	400006	2	Inner End Shield Plate
4.	400010	1	R.H. Inside Shield Angle
5.	400015	1	L.H. Inside Shield Angle
6.	400144	1	R.H. Auger Hold Arm
7.	400025	1	L.H. Auger Hold Arm
8.	400019	2	Auger Bearing Adjustment Plate
9.	102088	2	1-3/8 Flange Bearing
10.	400005	1	R.H. Vertical Adjustment Support Arm
11.	400405	1	L.H. Vertical Adjustment Support Arm
12.	118047	2	1/2" x 6" Rod End
13.	119161	2	Auger Tension Spring (11-1/2" LG)
14.	103100	1	# 60 Regular Chain
15.	119202	1	Sprocket, 60SF-80
16.	119158	1	Bushing, SF x 1-3/8"
17.	119016	2	60 Idler Sprocket (11 tooth)
18.	400155	1	Double Idler Mount
19.	400154	1	Double Idler Pilot Bushing (1" O.D. x 2" LG.)
20.	400107	1	R.H. Solid Bottom Cover Plate (148" Model)
21.	400110	1	Universal Center Solid Bottom Cover Plate
22.	400105	1	L.H. Solid Bottom Cover Plate (148" Model)
23.	400042	1	R.H. Clean Off Angle (148" Model)
24.	400044	1	L.H. Clean Off Angle (148" Model)
25.	400032	1	Front Clean Off Angle (148" Model)
26.	400352	2	Universal Platform Stand Assembly
27.	940290	1	R.H. Universal Knife Mount
28.	940289	1	L.H. Universal Knife Mount
29.	400320	1	Chain Guard
30.	102197	1	Bushing, SH x 1-3/8"
31.	119269	1	Sprocket, 60SH-14
32.	119147	1	6-Spline Shaft (12" w/keyway)
33.	102194	2	1-3/8" Pillow Block Bearing (2007-Present)
34.	400020	2	Driveline Shaft Mounting Plate (1997-2006)
35.	102090	2	1-3/8" Bearing Insert (1997-2006)
36.	106049	2 pair	72 MS Flangette (3 Hole) (1997-2006)
37.	400058	1	R.H. Replacement Perforated Bottom (148" Model)
38.	400057	1	L.H. Replacement Perforated Bottom (148" Model)
39.	400056	2	Hitch Pin Wear Plate
40.	104019	1	Driveline, 1 3/8" 21 Spline Yoke to 6-Spline Radial Pin Clutch (40)

UNIVERSAL PLATFORM—148" (1997–Present)**Parts List**

<u>Item No.</u>	<u>Part No.</u>	<u>Qty.</u>	<u>Description</u>
41.	124013	1	Radial Pin Clutch
42.	103078	2	Cross and Bearing Kit
43.	124014	1	Yoke, 1 3/8" 21 Spline (Standard)
43a.	124011		Yoke, 1 1/8" Hex (Optional)
43b.	124002		Yoke, 1 3/8" 6 Spline (Optional)
44.	400070	1	Case Adapter Plate (Optional)(Prior to 2003 AFX8010 & 2007 AFX7010)
45.	400118	1	R.H. Auger Flight (Long Bolt-on Section)
46.	400117	1	L.H. Auger Flight (Long Bolt-on Section)
47.	400256	1	R.H. Auger Flight (Short Bolt-on Section)
48.	400255	1	L.H. Auger Flight (Short Bolt-on Section)

Fingered portion of Auger can be ordered 28" to 48" in width

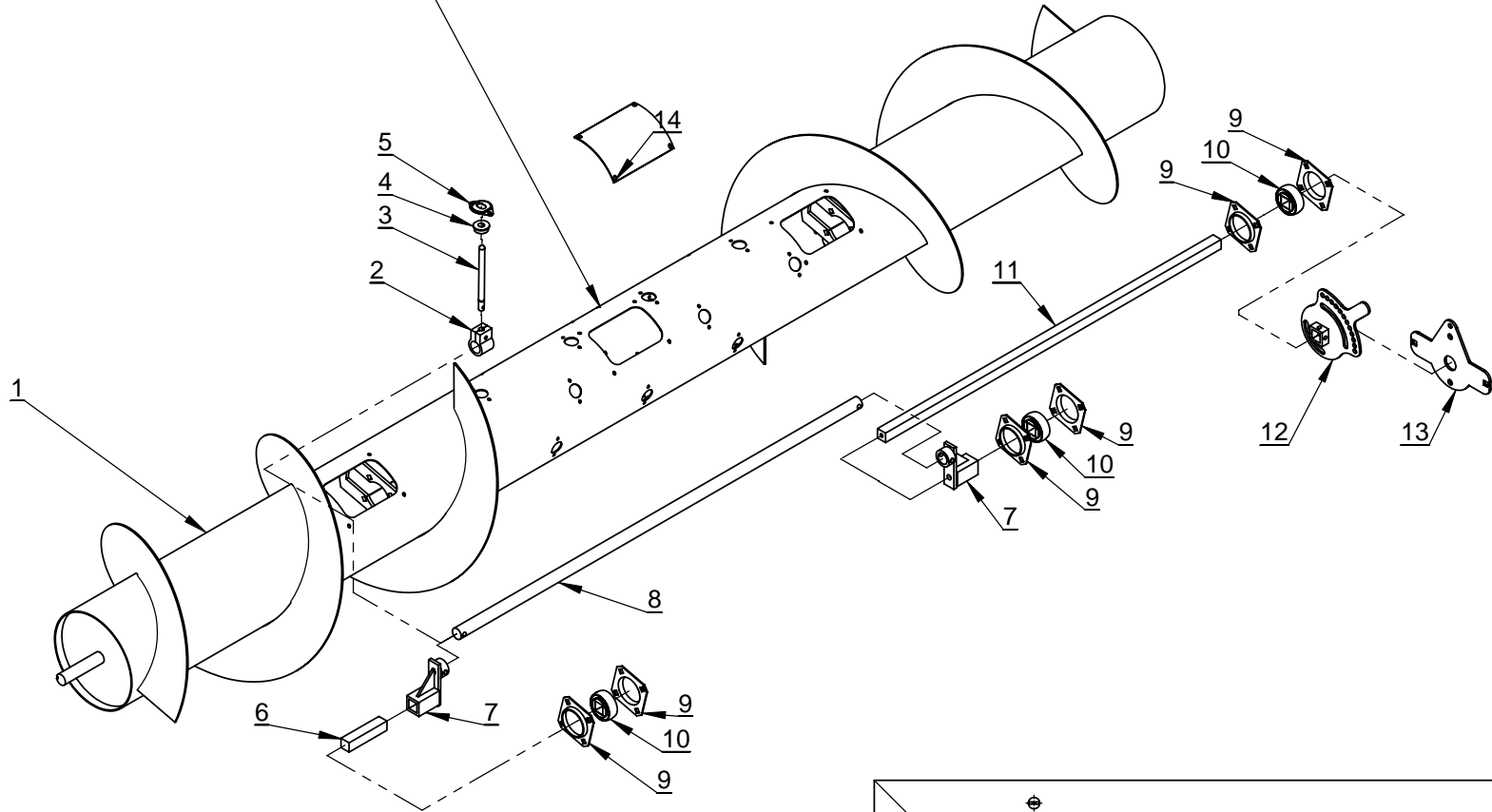

Universal Platform
Retractable Finger Auger
148" Model

Fingered Auger 148" Model

Parts List

<u>Item No.</u>	<u>Part No.</u>	<u>Qty</u>	<u>Description</u>
1.	400339	1	Retractable Finger Auger Weld Assembly
2.	103181	14—24	Finger Clamp Assembly
3.	116034-S	14—24	Steel Auger Finger
4.	400322	14—24	Steel Auger Finger Guide
5.	103182	14—24	Finger Guide Retainer
6.	400331	1	RH Idler Bearing Bar
7.	400330	2	Finger Crank Offset Arm Assembly
8.	400323	1	Finger Crank Center Shaft
9.	106066	3 pr	Flangette, 85MS
10.	102087	3	Bearing, 1 1/4" Square
11.	400326	1	LH Idler Bearing Bar (148" Model)
12.	400349	1	Idler Bar Lock Plate Assembly
13.	400351	1	Auger Finger Adjustment Plate
14.	400343	6	Access Hole Inspection Cover
15.	400335	1	Complete Retractable Finger Auger Assembly (Not Shown)

Roller Carriers

Not Shown	400060	1	Auger Carrier (Drive-end keyed)
Not Shown	400065	1	Auger Carrier (Idler-end no key)(Augers without retractable fingers)

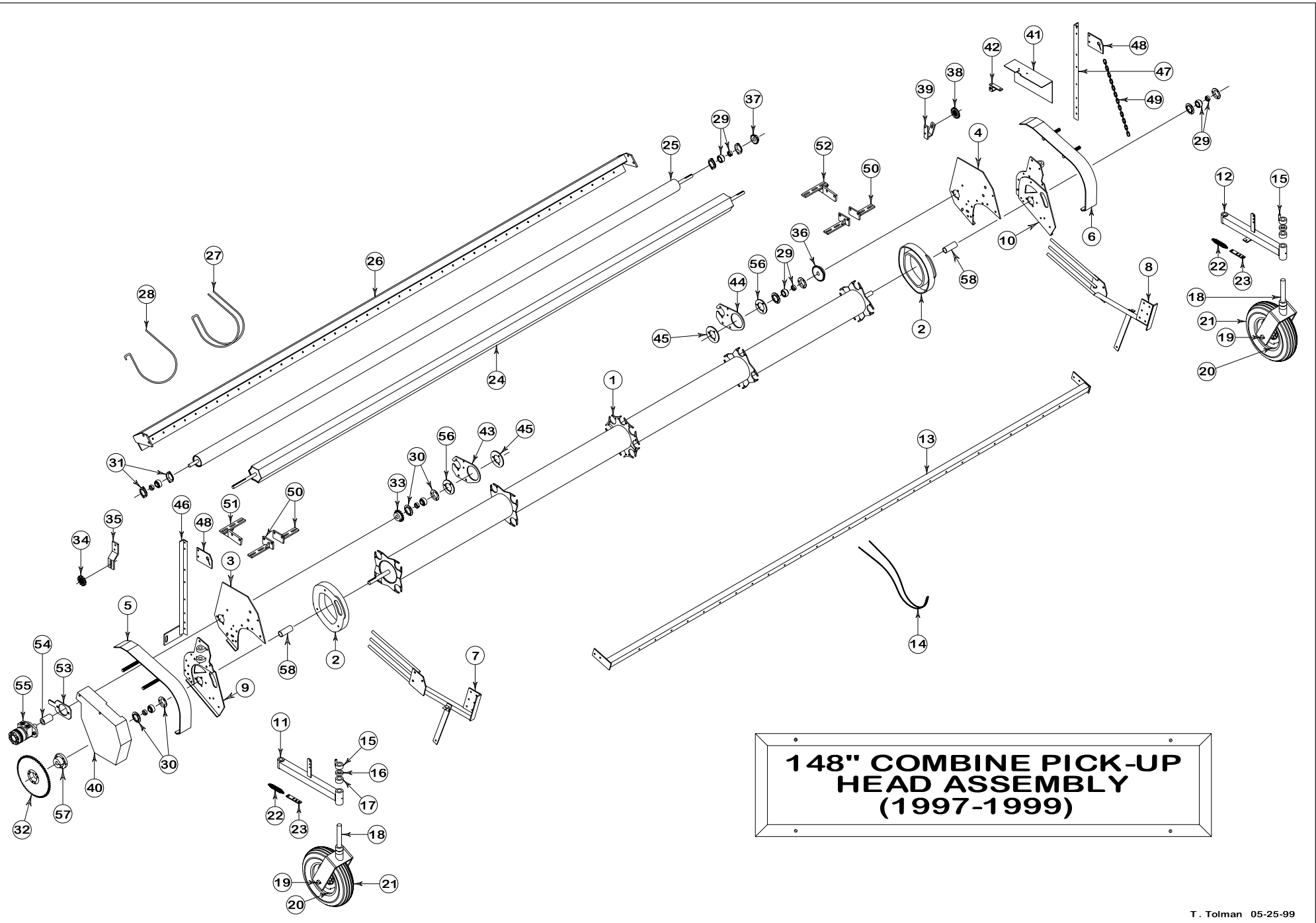

**148" COMBINE PICK-UP
HEAD ASSEMBLY
(1997-1999)**

148 ” (14 ft.) COMBINE PICK UP HEAD, (1997–1999)**(1” PUH Bearings)****Parts List**

Item No.	Part No.	Description
1.	940150-97	4-Tube Pickup Head (See pages 11–12) (1" PUH bearings)
1a.	940380	8-Tube Pickup Head (Not Shown) (See pages 16–17) (1" PUH bearings)
2.	103096	Cam Track, Universal
3.	901405	R.H. Rear Side Plate*
4.	901406	L.H. Rear Side Plate*
5.	900414	R.H. Roller Shroud
6.	900413	L.H. Roller Shroud
7.	940270	R.H. Side Plate Deflector Rod
8.	940269	L.H. Side Plate Deflector Rod
9.	940359	R.H. Front Side Plate (1" PUH bearings)
10.	940360	L.H. Front Side Plate (1" PUH bearings)
11.	940280★	R.H. Gauge Wheel Arm (Requires swivel pin # 940292)
12.	940295★	L.H. Gauge Wheel Arm (Requires swivel pin # 940292)
13.	940306	Hold Down Rod Mount Bracket
14.	118002	Hold Down Rod
15.	940017★	Spring Mount Lock Bushing
16.	940013★	Wheel Mount Spacer (½")
17.	940014★	Wheel Mount Spacer (1")
18.	940405★	Wheel Fork Assembly (Wide Frame) (1999 only)
18a.	940175★	Wheel Fork Assembly (Narrow Frame) (1997–1998)
19.	990080	Wheel Fork Axle (Requires 1" NF Castellated Hex Nut & ¼" Roll Pin) (1999–Present)
19a.	940177	Wheel Fork Axle (Requires 1" NF Castellated Hex Nut & ¼" Roll Pin) (1997–1998)
20.	123018	Steel Wheel 8 x 7 (5 on 4.5) (use bushing nos. 990137 & 990138) (1999–Present)
20a.	123016	Steel Wheel 8 x 4 (5 on 4.5) (use bushing nos. 940178 & 940179) (1997–1998)
Not Shown	108136	Straddle Hub (used with items: 18, 19, 20, 21)
Not Shown	102001	1" Straddle Hub Bearing cone (4 required)
Not Shown	102002	1" Straddle Hub Bearing cup (4 required)
Not Shown	119024	Hub Seal (4 required)
21.	120000	Tire (18 x 9.5—8) (1999–Present)
21a.	120010	Tire (4 x 8) (1997–1998)
Not Shown	123019	Wheel Assembly (Complete) (items: 20 & 21) (1999–Present)
Not Shown	123017	Wheel Assembly (Complete) (items: 20a & 21a) (1997–1998)
22.	119060	Wheel Mount Spring
23.	940018	Wheel Fork Spring Mount
24.	940071	Hex Roller
25.	940072	4" Roller
26.	940073	Rotor Rod Mount
27.	118015	Rotor Rod
Not Shown	103023	Rotor Rod Clip (3 hole)
28.	118016	Rotor Rod (R.H. End Only)

148 ” (14 ft.) COMBINE PICK UP HEAD, (1997–1999)**(1” PUH Bearings)****Parts List**

<u>Item No.</u>	<u>Part No.</u>	<u>Description</u>
Not Shown	103024	Rotor Rod Clip (2 hole) (R.H. End Only)
29.	102005	Bearing, 1” Insert with Lock Collar
30.	106004	Flangette, Housing (3 Hole)
31.	106013	Flangette, Housing (2 Hole)
32.	119148	Sprocket, 50 Q60 Taper Lock (SK Series) (replaces 119008)
33.	119166	Sprocket, 50BTB15H Taper lock (replaces 119006)
33a.	119163	Bushing, 1210 × 1 KW Taper lock (replaces 119006)
34.	119010	Idler Sprocket (50 BS 13)
35.	900334	50 Idler Sprocket Mount
36.	119169	Sprocket, 40BTB30H Taper lock (sprocket only)
36a.	119164	Bushing, 1610 × 1 KW Taper lock
37.	119170	Sprocket, 40BTB17H Taper lock (sprocket only)
37a.	119163	Bushing, 1210 × 1 KW Taper lock
38.	119005	Idler Sprocket (40 BS 17)
39.	940170	40 Idler Sprocket Mount
Not Shown	103012	50 Chain (80 pins or 40 links)
Not Shown	103105	40 Chain (47 pins or 23-1/2 links)
40.	900316	50 Chain Guard
41.	940300	40 Chain Guard
42.	940304	40 Chain Guard Mount
43.	940293	R.H. End Hinge Bracket
44.	940002	L.H. End Hinge Bracket
45.	900571	Hinge Lock
46.	940054-97	Upright Angle, R.H. (1997–Present)
47.	940053	Upright Angle, L.H. (All Models)
48.	940052	Upper Chain Bracket
49.	103036	Lift Chain, 1/4”
50.	940265	Knife Support Bracket (Universal)
51.	940290	R.H. Knife Support (for use with Universal Header)
52.	940289	L.H. Knife Support (for use with Universal Header)
53.	900225	Hydraulic Motor Mount
54.	103017	1” × 3” Split Coupler
55.	113023	Hydraulic Motor (MF Series)
56.	900570	Hinge Spacer
57.	119149	Sprocket, 1” Taper lock Hub (SK Series) (replaces 119008)
58.	900709	Spacer, Pickup Head (3 ²⁹ / ₃₂ ” LG.) (1” I.D.)
*Not Shown	940400	Complete R.H. Side Plate Assembly (1” Bearing) (includes # 901405 & 940359)
*Not Shown	940401	Complete L.H. Side Plate Assembly (1” Bearing) (includes # 901406 & 940360)

★ When ordering parts verify year and wheel fork assembly shaft size. 1997–1999 the wheel fork pivot shaft is 1 ³/₁₆”. 2000–present the wheel fork pivot shaft is 1 ¹/₄”

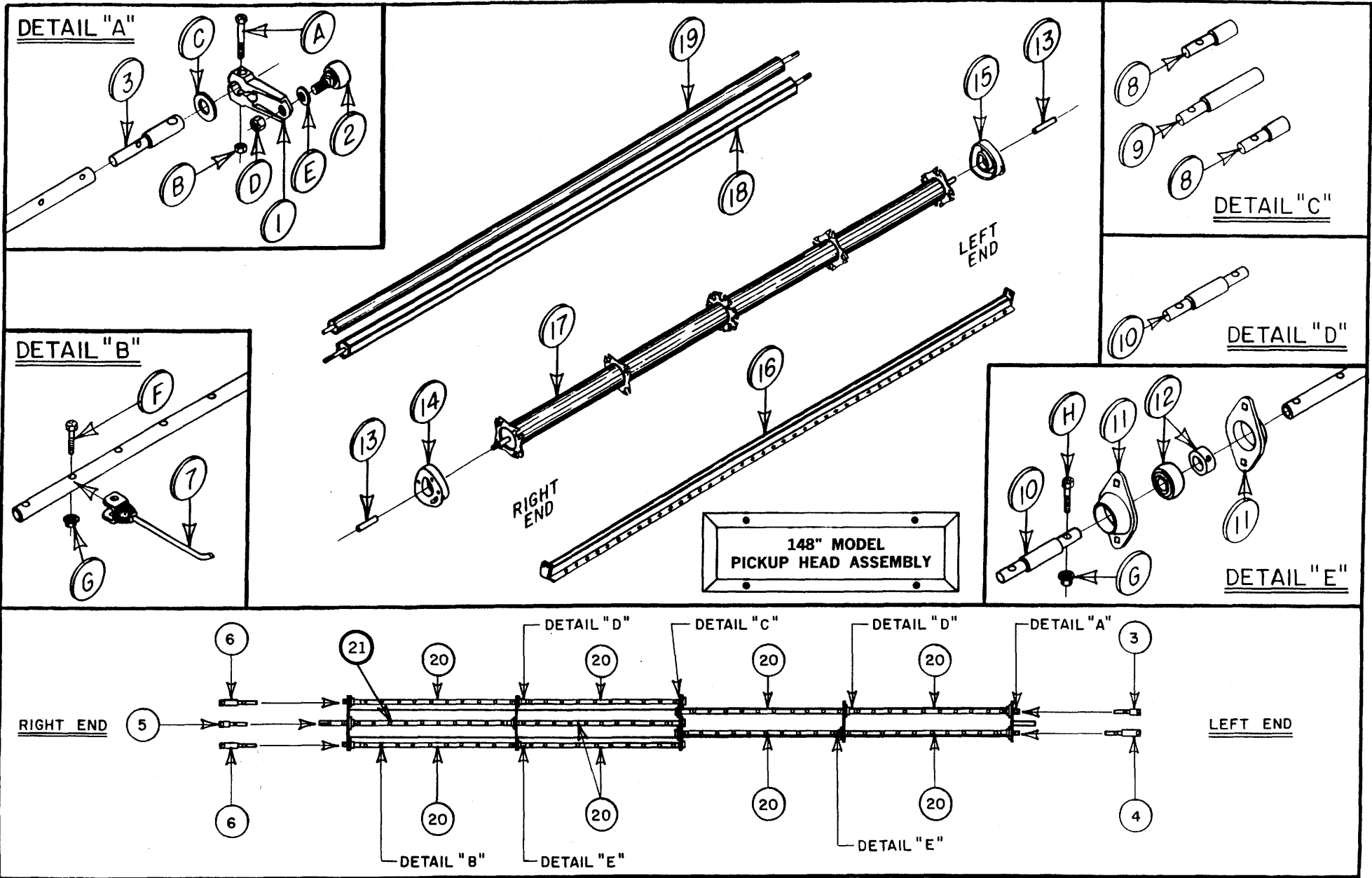

4 TUBE PICK UP HEAD ASSEMBLY 148" MODEL (1997–1999)

Parts List

<u>Item No.</u>	<u>Part No.</u>	<u>Description</u>
1.	103095	Cam Arm, Universal
2.	102015	Bearing, Cam Arm
3.	119137	Shaft, L.H. Short Finger Offset
4.	119135	Shaft, L.H. Long Finger Offset
5.	119136	Shaft, R.H. Short Finger Offset
6.	119134	Shaft, R.H. Long Finger Offset
7.	106000	Finger, Rubberized—146 Per machine
8.	900859	Center Spider Stub Shaft—Short
9.	900858	Center Spider Stub Shaft—Long
10.	900857	Coupler, Finger Rod
11.	106013	Flangett, 2-Hole
12.	102005	Bearing, 1" Insert with Lock Collar
13.	900709	Spacer, Pickup Head (3 ²⁹ / ₃₂ " Lg.) (1" I.D.)
14.	103096	Cam Track, Universal
15.	103096	Cam Track, Universal
16.	940073	Rotor Rod Mount
17.	940149	Pickup Tube with 5 Spiders (1" PUH bearings)
18.	940071	Hex Roller
19.	940072	4" Roller
20.	900897	Finger Rod, 33 ³ / ₈ "—14 Required per P.U.H.
21.	900866	Finger Rod, 37 ³ / ₈ "—2 Required per P.U.H.
Not Shown	940150-97	Complete Pickup Head Assembly (1" PUH bearings)
Not Shown	900860	Four-Hole End Spider
Not Shown	900861	Eight-Hole Center Spider

Hardware List

<u>Item No.</u>	<u>Part No.</u>	<u>Description</u>
A.		7/16" × 3" NC Hex Bolt—Grade 8
B.		7/16" NC Nyloc Hex Nut
C.		1" SAE Flat Washer
D.		5/8" NF Jam Nut
E.		5/8" Shim Washer, Optional
F.		5/16" × 1½" NC Hex Bolt—Grade 5 (For use on Fingers only)
G.		5/16" NC Whiz Nut
H.	106051	5/16" × 2" NF Hex Bolt—Grade 9 (For use on all couplers and stub shafts)
Ha.	106051	5/16" NF Stover Nut (Grade 9) (sold as a set with bolt)

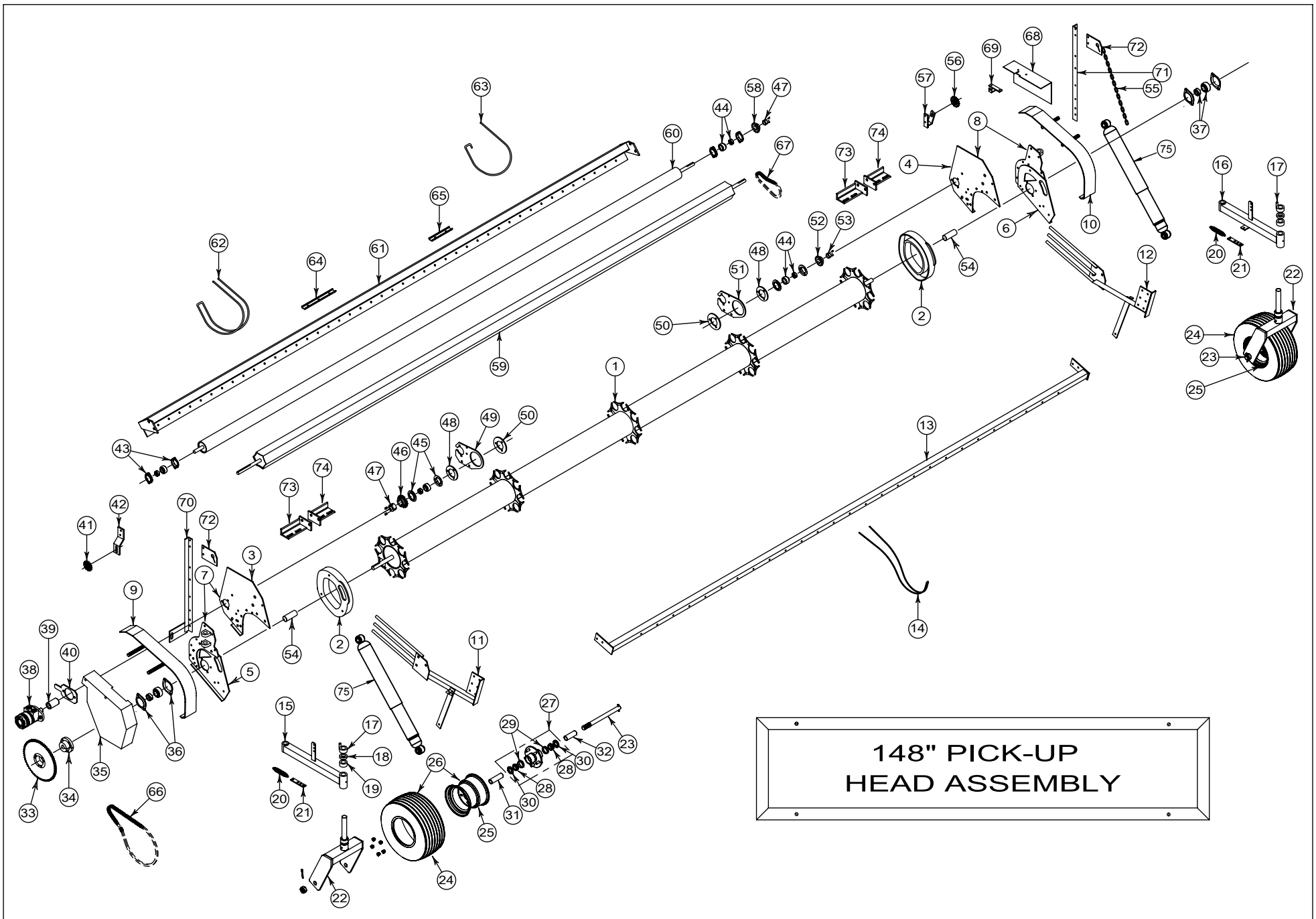

148" PICK-UP
HEAD ASSEMBLY

148" COMBINE PICKUP HEAD (2000-Present)**(1 1/4" PUH Bearings)****Parts List**

<u>Item No.</u>	<u>Part No.</u>	<u>Qty</u>	<u>Description</u>
1.	940380	1	8-Tube Pickup Head
2.	103096	2	Cam Track, Universal
3.	901405	1	R.H. Rear Side Plate
4.	901406	1	L.H. Rear Side Plate
5.	940395	1	R.H. Front Side Plate (1 1/4" PUH bearings)
6.	940396	1	L.H. Front Side Plate (1 1/4" PUH bearings)
7.	940402	1	Complete R.H. Side Plate Assembly (includes items 3 & 5)
8.	940403	1	Complete L.H. Side Plate Assembly (includes items 4 & 6)
9.	900414	1	R.H. Roller Shroud
10.	900413	1	L.H. Roller Shroud
11.	940270	1	R.H. Side Plate Deflector Rod
12.	940269	1	L.H. Side Plate Deflector Rod
13.	940306	1	Hold Down Rod Mount Assembly
14.	118002	24	Hold Down Rod
15.	940501	1	R.H. Gauge Wheel Arm (Requires swivel pin # 940292)
16.	940502	1	L.H. Gauge Wheel Arm (Requires swivel pin # 940292)
17.	940505	2	Spring Mount Lock Bushing
18.	940506	2	Wheel Mount Spacer (1/2")
19.	940507	6	Wheel Mount Spacer (1")
20.	119060	2	Wheel Mount Spring
21.	940018	2	Wheel Fork Spring Mount
22.	940500	2	Wheel Fork Assembly (Wide Frame)
23.	990080	2	Wheel Fork Axle (Requires 1" NF Slotted Hex Nut & 1/4" Roll Pin)
24.	120000	2	Tire (18 x 9.5—8)
25.	123018	2	Steel Wheel 8 x 7 (5 on 4.5)
26.	123019	2	Wheel Assembly (Complete) (items: 24 & 25)
27.	108136	2	Straddle Hub (includes items: 28, 29 & 30)
28.	102001	4	1" Straddle Hub Bearing cone
29.	102002	4	1" Straddle Hub Bearing cup
30.	119024	4	Hub Seal
31.	990137	2	Bushing, Spacer 4 -1/8" long
32.	990138	2	Bushing, Spacer 3 -9/16" long
33.	119148	1	Sprocket, 50QDSK60 Taper Lock (SK Series)
34.	119159	1	Sprocket, 1 1/4" Taper lock Hub
35.	900316	1	50 Chain Guard
36.	106050	2	Flangette, 2-Hole (72 MST)
37.	102060	2	Bearing, 1 1/4" Insert with Lock collar
38.	113023	1	Hydraulic Motor (MF Series)
38a.	119109		Seal Kit for Item 38
39.	103017	1	1" x 3" Split Coupler
40.	900225	1	Hydraulic Motor Mount

148" COMBINE PICKUP HEAD (2000-Present)**(1 1/4" PUH Bearings)****Parts List**

<u>Item No.</u>	<u>Part No.</u>	<u>Qty</u>	<u>Description</u>
41.	119010	1	Idler Sprocket (5013E10)
42.	900334	1	50 Idler Sprocket Mount
43.	106013	2	Flangette, Housing (2 Hole)
44.	102005	4	Bearing, 1" Insert with Lock Collar
45.	106004	2	Flangette, Housing (3 Hole)
46.	119166	1	Sprocket, 50BTB15H Taper lock
47.	119163	2	Bushing, 1210 x 1 KW Taper lock
48.	940668	2	Hinge Spacer (2016 – Present)
48a.	900570	2	Hinge Spacer (2000 – 2015)
49.	940666	1	R.H. End Hinge Bracket (2016 – Present)
49a.	940293	1	R.H. End Hinge Bracket (2000 – 2015)
50.	900571	2	Hinge Lock
51.	940665	1	L.H. End Hinge Bracket (2016 – Present)
51a.	940002	1	L.H. End Hinge Bracket (2000 – 2015)
52.	119170	1	Sprocket 40TBT17H Taper lock (2013 – Present)
52a.	119169	1	Sprocket, 40BTB30H Taper lock (2000 – 2012)
53.	119163	1	Bushing, 1210 x 1 KW Taper lock (2013 – Present)
53a.	119164	1	Bushing, 1610 x 1 KW Taper lock (2000 – 2012)
54.	901484	2	Spacer, Pickup Head
55.	103036	2	Lift Chain, 1/4"
56.	119005	1	Idler Sprocket (4017E08)
57.	940170	1	40 Idler Sprocket Mount
58.	119170	1	Sprocket, 40BTB17H Taper lock (sprocket only)
59.	940071	1	Hex Roller
60.	940072	1	4" Roller
61.	940073	1	Rotor Rod Mount
62.	118015	37	Rotor Rod
63.	118016	0	Rotor Rod Half (L.H. End Only)
64.	103023	11	Rotor Rod Clip (3 hole)
65.	103024	2	Rotor Rod Clip (2 hole) (L.H. End Only)
66.	103012	1	50 Chain (80 pins or 40 links)
67.	103199	1	40 Chain (40 pins or 20 links) (2013 – Present)
67a.	103105	1	40 Chain (47 pins or 23 1/2 links) (2000 – 2012)
68.	940300	1	40 Chain Guard
69.	940304	1	40 Chain Guard Mount
70.	940054-97	1	Upright Angle, R.H. (1997–Present)
71.	940053	1	Upright Angle, L.H. (All Models)
72.	940052	2	Upper Chain Bracket
73.	940265-R	2	R.H Knife Support Bracket
74.	940265-L	2	L.H. Knife Support Bracket
75.	119348	2	Shock, Gas Charged (2013 – Present)

DETAIL "A"

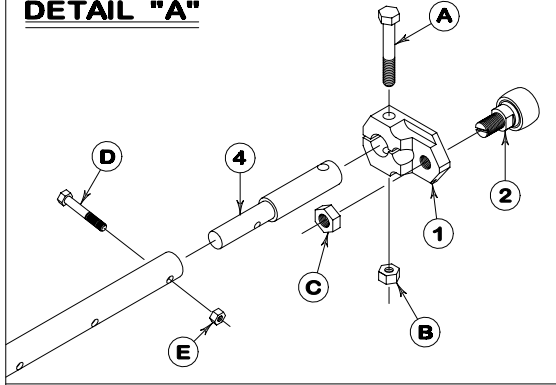

FINGER RODS REQUIRED PER (148-3/16") 8 TUBE P-U HEAD

- (4 REQ'D) 37-3/8" (10 HOLES) 900866
- (28 REQ'D) 33-3/8" (9 HOLES) 900897

DETAIL "C"

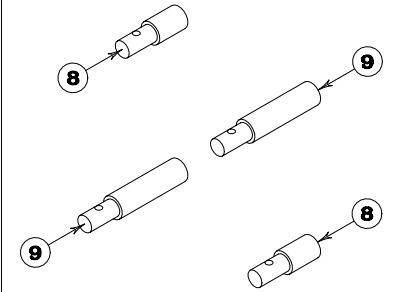

DETAIL "D"

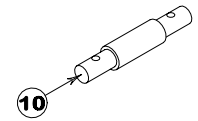

DETAIL "E"

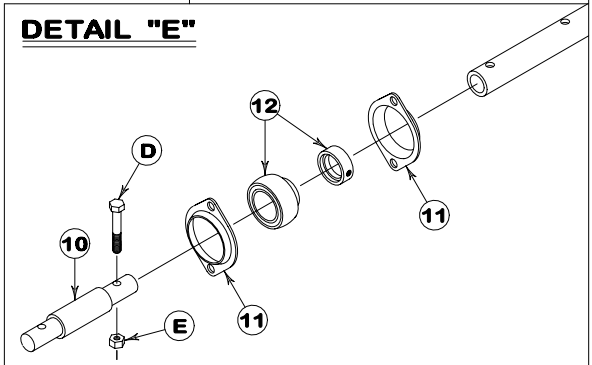

DETAIL "B"

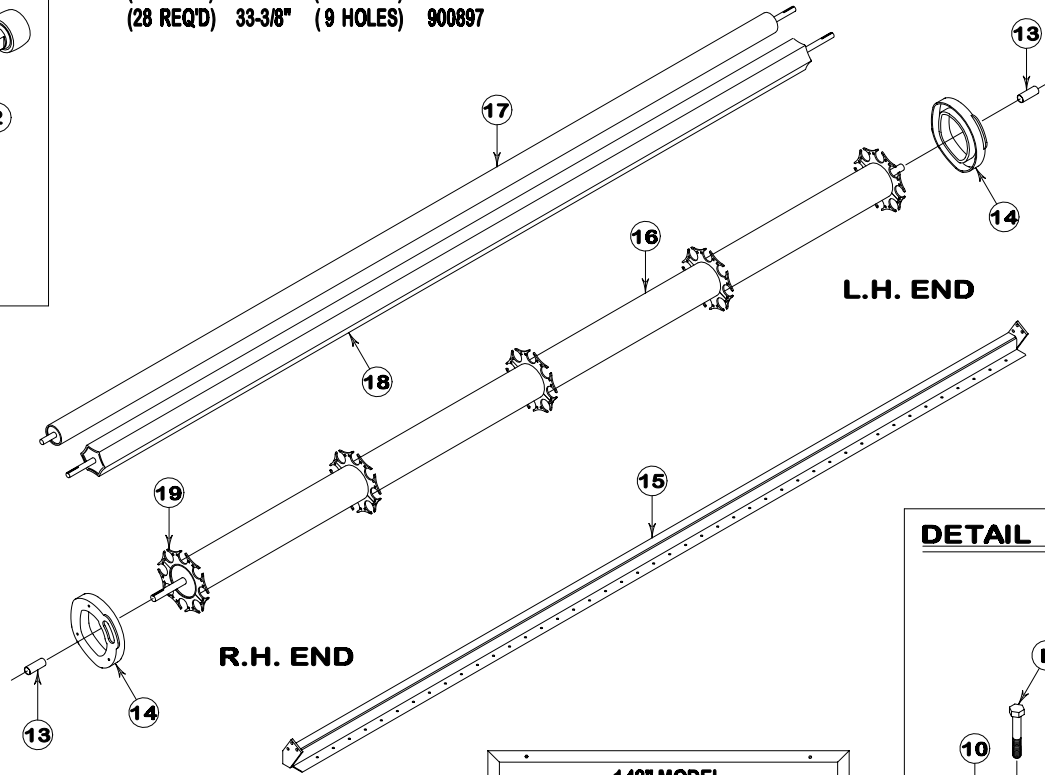
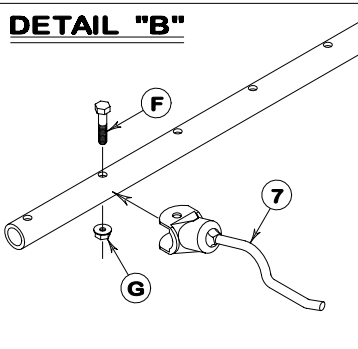

148" MODEL
8 TUBE PICK-UP HEAD ASSEMBLY

L.H. END (NO KEY)

R.H. END (KEYED)

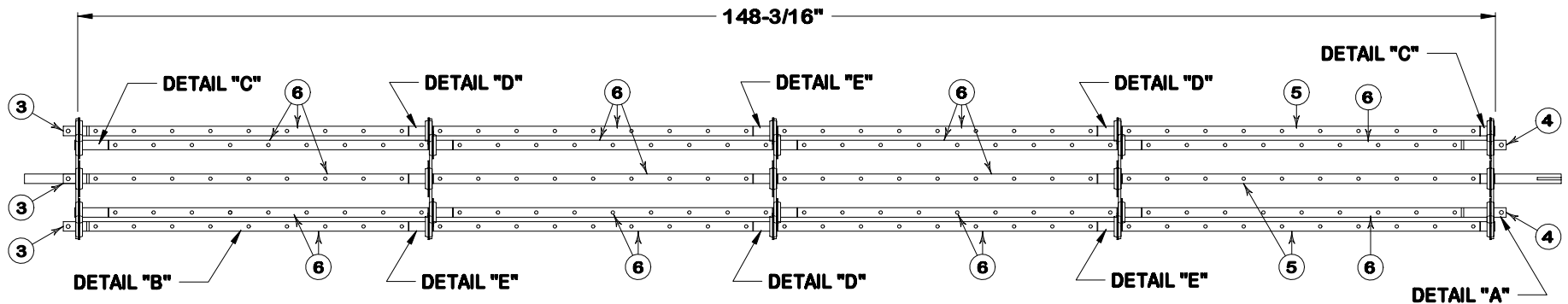

8-TUBE PICKUP HEAD ASSEMBLY (148" MODEL) 1997–2014

Parts List

<u>Item No.</u>	<u>Part No.</u>	<u>Qty</u>	<u>Description</u>
1.	103095	8	Cam Arm (Universal)
2.	102015	8	Bearing, Cam Arm
3.	119137	4	Shaft, L.H. Short Finger Offset
4.	119134	4	Shaft, R.H. Long Finger Offset
5.	900866	4	Finger Rod 37 ³ / ₈ " (10 Holes)
6.	900897	28	Finger Rod 33 ³ / ₈ " (9 holes)
7.	106036	292	Finger, with radius (8-Tube Pickup Head)
8.	901412	4	End Spider Stub Shaft (short)
9.	901420	4	End Spider Stub Shaft (long)
10.	900857	24	Coupler, Finger Rod
11.	106013	40 pr.	Flangett, 2 Hole
12.	102005	40	Bearing, 1" Insert (with Lock Collar)
13.	901484	2	Spacer, Pickup Head (3 ²⁹ / ₃₂ " Lg.)(1 ¹ / ₄ " I.D.)
13a.	900709	2	Spacer, Pickup Head (3 ²⁹ / ₃₂ " Lg.)(1" I.D.)
14.	103096	2	Cam Track (Universal)
15.	940073	1	Rotor Rod Mount (154 ³ / ₄ "
16.	940379	1	Pickup Tube (with 5 Spiders) (148 ³ / ₁₆ ") (1" PUH bearings)
16a.	940379-00	1	Pickup Tube (with 5 Spiders) (148 ³ / ₁₆ ") (1 ¹ / ₄ " PUH bearings)
17.	940072	1	4" Roller (152 ⁷ / ₈ "
18.	940071	1	Hex Roller (150 ³ / ₈ "
19.	900861	5	Eight Hole Spider
Not Shown	940380	1	Complete 8-Tube Pickup Head Assembly (148 ³ / ₁₆ ") (1" PUH bearings)
Not Shown	940380-00	1	Complete 8-Tube Pickup Head Assembly (148 ³ / ₁₆ ") (1 ¹ / ₄ " PUH bearings)
<u>Roller Carriers</u>			
Not Shown	901450	1	1 ¹ / ₄ " Pickup Head Carrier (Drive-end keyed)
Not Shown	901451	1	1 ¹ / ₄ " Pickup Head Carrier (Idler-end no key)
Not Shown	900058	1	4" Roller Carrier (Drive-end keyed)
Not Shown	900059	1	4" Roller Carrier (Idler-end no key)
Not Shown	900062	1	Hex Roller Carrier (R.H. end 4 ³ / ₄ " keyway)
Not Shown	900063	1	Hex Roller Carrier (L.H. end 2 ¹ / ₂ " keyway)
Not Shown	900044	1	1" Pickup Head Carrier (Drive-end keyed)
Not Shown	900045	1	1" Pickup Head Carrier (Idler-end no key)

Hardware List

<u>Item No.</u>	<u>Part No.</u>	<u>Qty</u>	<u>Description</u>
A.		8	7/16" × 3" NC Hex Bolt–Grade 8
B.		8	7/16" NC Nylon Hex Nut
C.		8	5/8" NF Jam Nut
D.	106051	64	5/16" × 2" NF Hex Bolt–Grade-9 (sold as a set with nut)
E.	106051	64	5/16" NF Stover Nut–Grade9 (sold as a set with bolt)
F.		228	5/16" × 1 ¹ / ₂ " NC Hex Bolt–Grade-5 (use on fingers only)
G.		228	5/16" NC Whiz Nut (use on fingers only)

DETAIL "A"

FINGER RODS REQUIRED PER (148-3/16") 8 TUBE P-U HEAD

(4 REQ'D)	37-3/8"	(10 HOLES)	900866
(28 REQ'D)	33-3/8"	(9 HOLES)	900897

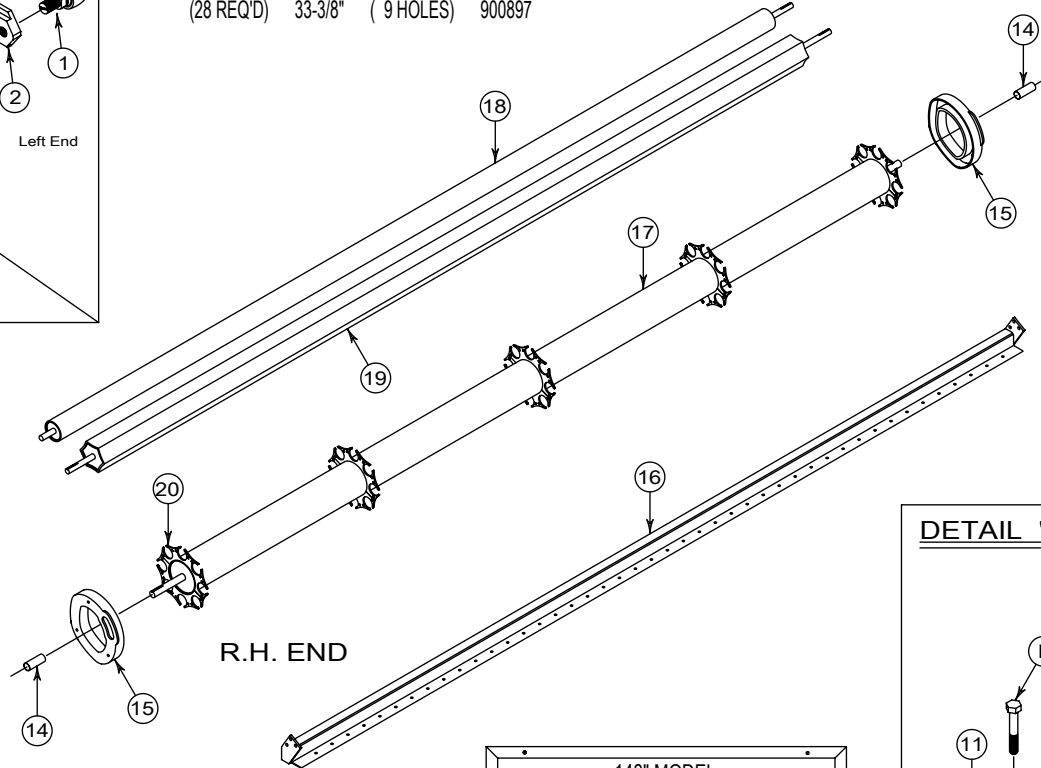
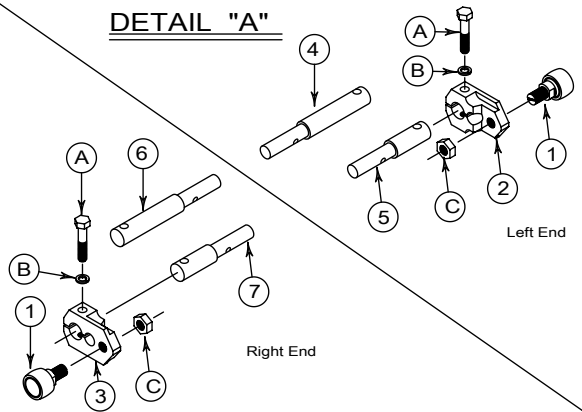

DETAIL "C"

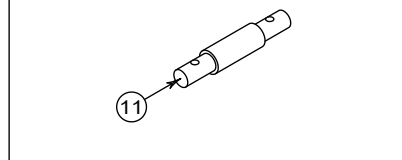

DETAIL "B"

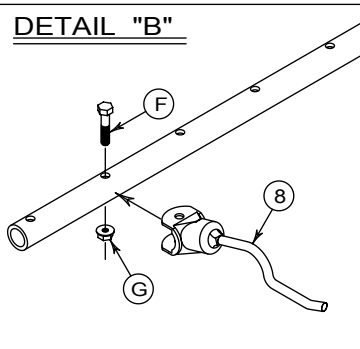

DETAIL "D"

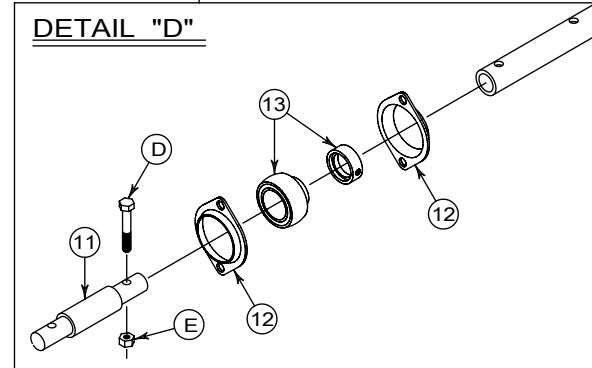

148" MODEL
8 TUBE PICK-UP HEAD ASSEMBLY

L.H. END (NO KEY)

R.H. END (KEYED)

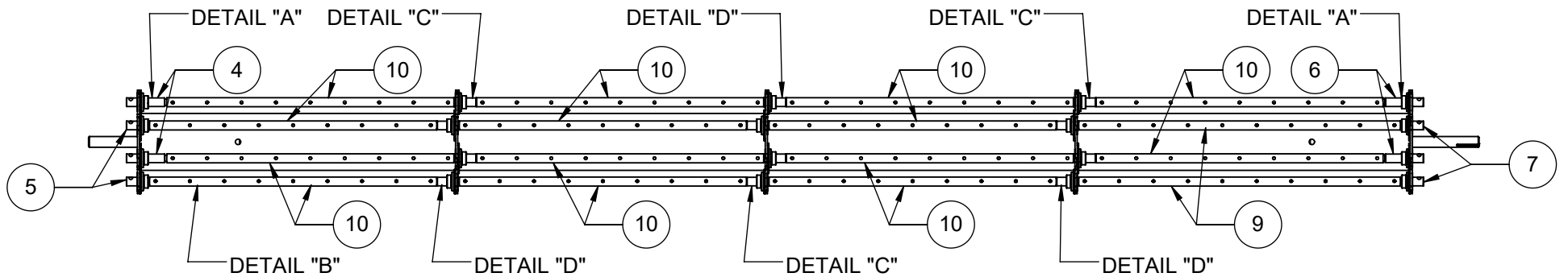

8-TUBE PICKUP HEAD ASSEMBLY (148" MODEL) 2015–Present

Parts List

<u>Item No.</u>	<u>Part No.</u>	<u>Qty.</u>	<u>Description</u>
1.	102015	16	Bearing, Cam Arm
2.	103095-LH	8	Cam Arm (Threaded)
3.	103095-RH	8	Cam Arm (Threaded)
4.	119135	4	Shaft, L.H. Long Finger Offset
5.	119137	4	Shaft, L.H. Short Finger Offset
6.	119134	4	Shaft, R.H. Long Finger Offset
7.	119136	4	Shaft, R.H. Short Finger Offset
8.	106036	292	Finger, with radius (8-Tube Pickup Head)
8a.	106052	0	Finger, Soft (Optional)
9.	900866	4	Finger Rod 37 ³ / ₈ " (10 holes)
10.	900897	28	Finger Rod 33 ³ / ₈ " (9 holes)
11.	900857	24	Coupler, Finger Rod
12.	106013	40Pr.	Flangette, 2 Hole
13.	102005	40	Bearing, 1" Insert (with Lock Collar)
14.	901484	2	Spacer, Pickup Head (3 ²⁹ / ₃₂ " Lg.)(1 1/4" I.D.)
15.	103096	2	Cam Track (Universal)
16.	940073	1	Rotor Rod Mount (154 ³ / ₄ "
17.	940379	1	Pickup Tube (with 5 Spiders) (148 ³ / ₁₆ " (1 1/4" PUH Bearings)
18.	940072	1	4" Roller (152 ⁷ / ₈ "
19.	940071	1	Hex Roller (150 ³ / ₈ "
20.	900861	5	Eight-Hole Spider
Not Shown	940380-A	1	Complete 8-Tube Pickup Head Assembly (148 ³ / ₁₆ " (1 1/4" PUH Bearings)

Roller Carriers

Not Shown	901450	1	1 1/4" Pickup Head Carrier (Drive-end keyed)
Not Shown	901451	1	1 1/4" Pickup Head Carrier (Idler-end no key)
Not Shown	900058	1	4" Roller Carrier (Drive-end keyed)
Not Shown	900059	1	4" Roller Carrier (Idler-end no key)
Not Shown	900062	1	Hex Roller Carrier (R.H. end 4 ³ / ₄ " keyway)
Not Shown	900063	1	Hex Roller Carrier (L.H. end 2 1/2" keyway)

Hardware List

<u>Item No.</u>	<u>Part No.</u>	<u>Qty.</u>	<u>Description</u>
A.		16	7/16" × 2 1/4" NF Hex Bolt–Grade 8
B.		16	7/16" Lock Washer
C.		16	5/8" NF Jam Nut
D.	106051	64	5/16" × 2" NF Hex Bolt–Grade 9 (sold as a set with nut)
E.	106051	64	5/16" NF Stover Nut–Grade 9 (sold as a set with bolt)
F.		228	5/16" × 1 1/2" NC Hex Bolt–Grade 5 (use on fingers only)
G.		228	5/16" NC Whiz Nut (use on fingers only)